



Versatile, economical, professional  
Cold Milling Machine W 2000



# Always in top shape – high-performance cold milling machine W 2000

Its versatility makes this large milling machine so efficient

For professional contractors requiring a versatile road milling machine with high performance reserves, the tried and tested W 2000 paves the way to an all-round success. This multi-purpose machine in the range of Wirtgen large milling machines of the 2-m class achieves excellent results in particular in the removal of pavement surfaces on a large scale – the state-of-the-art, robust diesel engine provides sufficient power regardless of the job at hand.

In addition, the innovative FCS Light ensures that even micro-fine milling jobs are completed to the highest quality standards. At the end of the day, it is the wide range of applications that makes the compact W 2000 such an economically efficient machine.



^  
The W 2000 front loader proves to be a master of its craft on all kinds of milling sites.

>  
Reliable machine technology and a new, appealing design.





### Working width of 2.20 m as an option

- The Wirtgen Flexible Cutter System Light (FCS Light) greatly enlarges the range of applications of the W 2000.
- The working width can optionally be extended to 2.20 m to enable even more applications and make the machine even more efficient.
- The LEVEL PRO automatic levelling system guarantees accurate, high-quality milling results.
- The experience and expertise gained in the manufacture of over a thousand W 2000 machines and in countless jobs have been utilized to the benefit of this highly mature machine.



# Compact 2-m milling machine with high performance reserves

## At home on construction sites big and small

Its milling width of 2 m and high engine power enable the W 2000 to mill large areas economically at maximum milling depths of up to 320 mm. Our large milling machine stands up to any comparison – regardless of whether the job demands the milling of individual pavement layers or the removal of entire road pavements. However its high milling performance and compact design also ensure swift job completion on small or medium-sized milling sites, such as the rehabilitation of an inner-city road pavement.

Moreover the W 2000 is eminently suitable for the low-cost rehabilitation of road surfaces by fine milling. The performance diagram of the W 2000 can be used to roughly estimate the machine's theoretical milling performance.







The W 2000 large milling machine efficiently removes complete road pavements ...



... as well as individual pavement layers.

Theoretical milling performance of the W 2000.

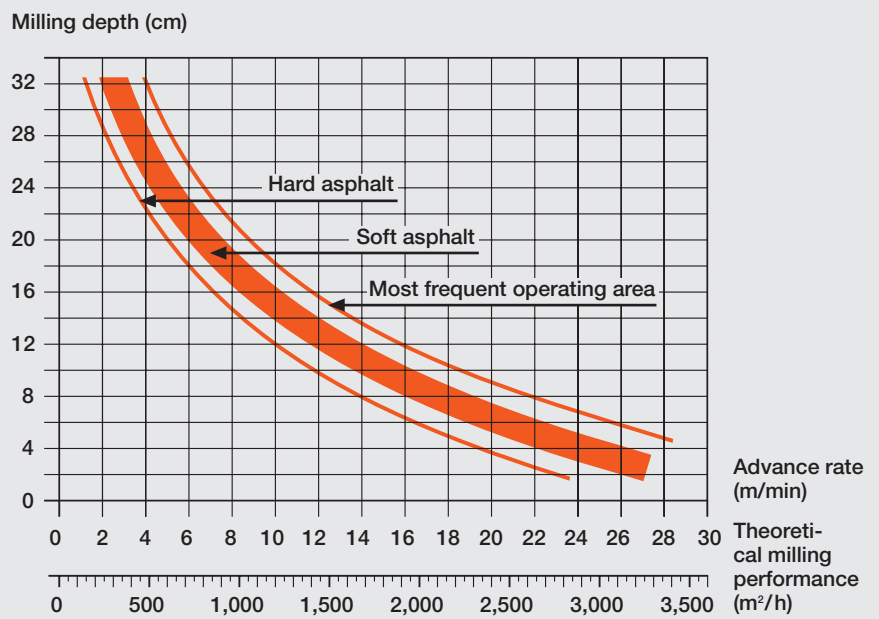

# Effortless control of the milling process



^  
The control panel has been designed with functionality in mind and is adjustable in height and tilt.

Move control panel plus canopy  
outwards – while retaining a perfect  
view of the milling edge.

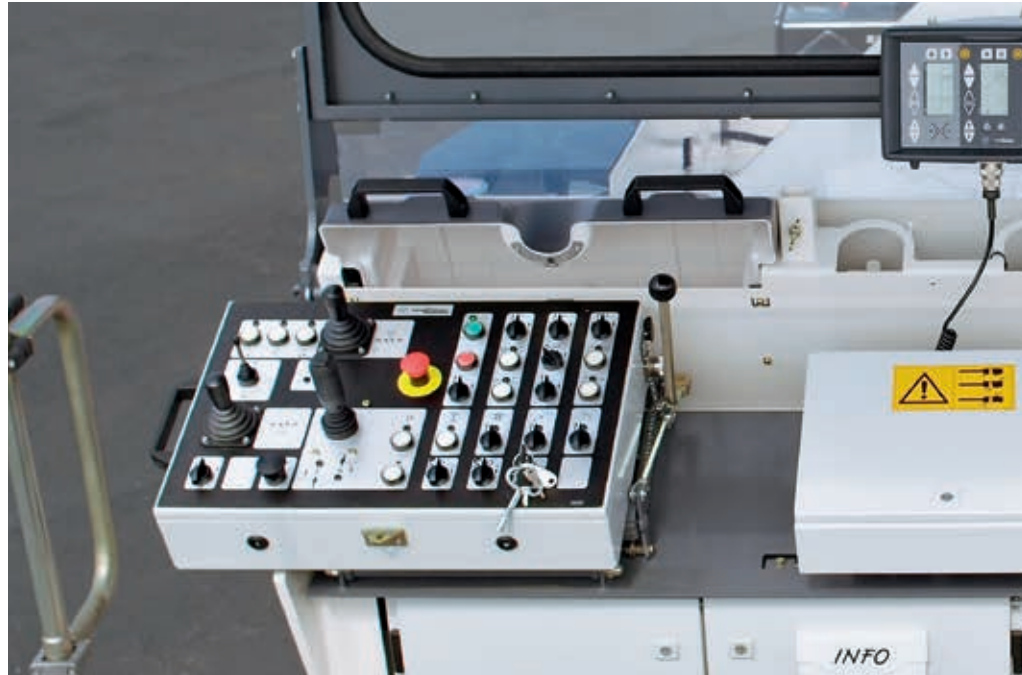

^  
Both control panels can be  
moved out over the edge  
of the machine.

>  
The hydraulically retractable  
canopy is folded down into  
transport position at the mere  
flick of a switch.







## Mastering operation of the W 2000 quickly

Easy handling of the W 2000 enables highly productive work right from the start. Clearly arranged controls allow the large milling machine to be operated intuitively while the unambiguous symbols provide clarity and safety. In addition, the proprietary WIDIS 32 on-board information and diagnostic system developed by Wirtgen displays all parameters pertaining to the machine, engine and hydraulic system.



Ergonomic standards play an important role, too: anti-vibration mounted treads on the walk-through operator's platform add to the high degree of operator comfort. Last but not least, the control panels and driver's seats can be adjusted individually to allow efficient working in both standing and seated position.

# LEVEL PRO guarantees top-class milling results

## Maximum ease of levelling

Wirtgen has developed a highly accurate, proprietary levelling system including a software that has been designed specifically for cold milling machines: LEVEL PRO. The overall system includes an operating panel, a controller unit and several sensors. The graphics-enabled LEVEL PRO screen shows key parameters in a clearly legible fashion.

For example, target and actual values for the left and right milling depth and slope parameters are clearly and unambiguously shown on the displays. In addition, the memory feature is very useful to program, store and invoke target values.



^ The control panel has been mounted in the operator's direct field of view.

> The optional electronic slope sensor for milling pre-set cross slopes.







Scanning the surface in front of the milling drum using a wire-rope sensor (optional).

Wire-rope sensors attached to the side plates accurately measure the milling depth on both sides.

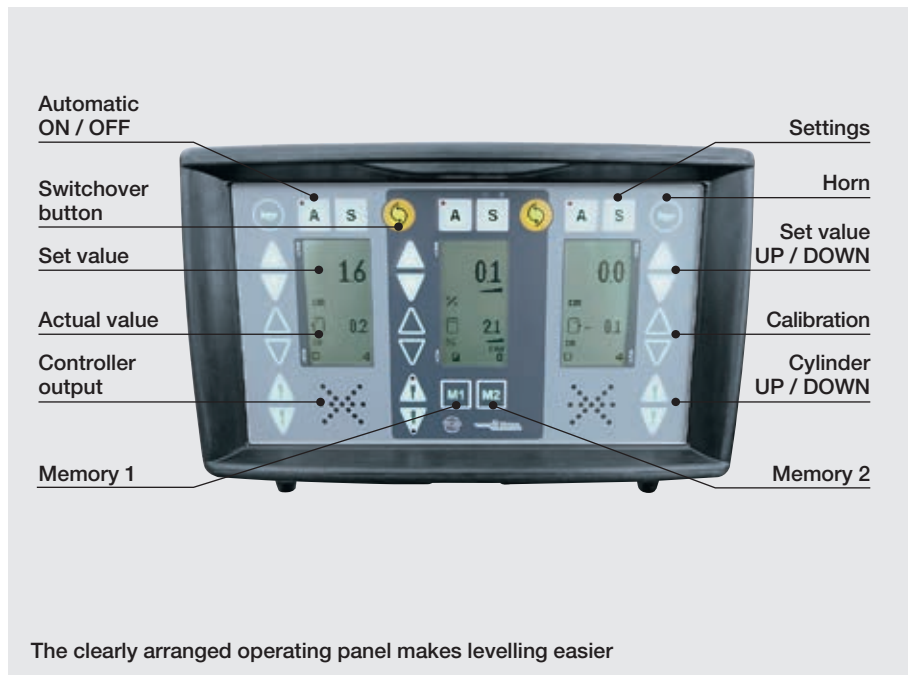

- Automatic ON / OFF
- Switchover button
- Set value
- Actual value
- Controller output
- Memory 1
- Settings
- Horn
- Set value UP / DOWN
- Calibration
- Cylinder UP / DOWN
- Memory 2

The clearly arranged operating panel makes levelling easier

### Maximum ease of levelling

- › Large tactile switches enable the operator to enter or correct parameters quickly and safely.
- › The optional multiplex system can be used to perfectly compensate irregularities in longitudinal direction.
- › A great variety of sensors can be integrated into the automatic levelling system as and when required, such as wire-rope, slope and ultrasonic sensors.
- › The multiplex system analyses the output of three, five or seven sensors on each side of the machine, which is very useful to ensure perfectly level surfaces during fine milling.



# Wide range of applications ensures efficiency

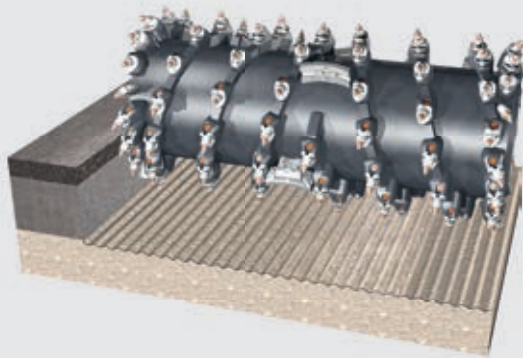

**ECO cutter**  
Milling width: 2,000 mm  
Milling depth: 0–320 mm  
Tool spacing: 25 mm

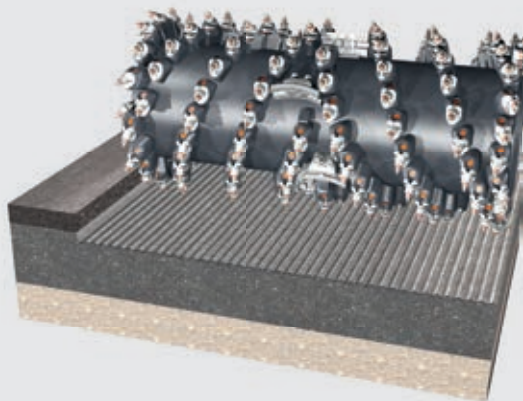

**Standard milling drum**  
Milling width: 2,000 mm  
Milling depth: 0–320 mm  
Tool spacing: 15 mm

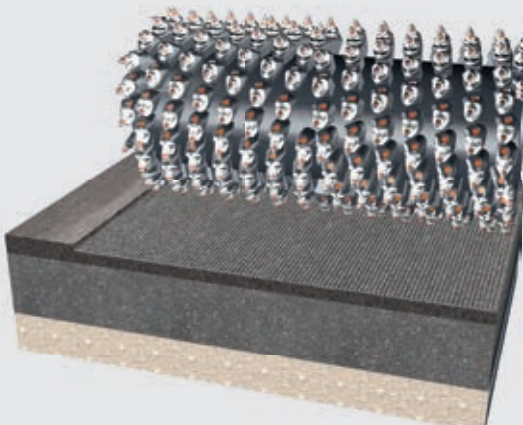

**Fine milling drum**  
Milling width: 2,000 mm  
Milling depth: 0–100 mm  
Tool spacing: 8 mm





^  
The scraper blade can be swung open hydraulically for cutting tool replacement.

## Adds even more versatility: the 2.20 m housing

Versatility is what makes a cold milling machine economical! The Flexible Cutter System Light (FCS Light) enables the W 2000 to be equipped with milling drums of various tool spacings. From deep milling using the eco cutter or standard milling drum to fine milling or micro-fine milling – the W 2000 completes a wide range of demanding jobs all on its own. In addition, a housing extension

enables the W 2000 to be upgraded for 2.20 m wide milling drums – for an even wider range of applications and greater efficiency. It goes without saying that both side plates are hydraulically adjustable in height. The same applies to the scraper blade: it can be hydraulically adjusted in height in order to load all or part of the milled material, or to leave it completely behind in the milled track.

<  
Range of milling drums for the W 2000 with a working width of 2 m.

# HT22 makes operation of the W 2000 even more economical

## Long service life in even the toughest jobs

Toolholders are subject to a high degree of stress and strain. Our patented HT22 quick-change toolholder system has been designed for demanding everyday use on the construction site, extending uptimes and significantly cutting operating costs. Clear marks in favour of the HT22 system are the use of particularly wear-resistant materials, additional tool cooling enabled by an optimized toolholder design, as well as ease of use and maintenance.

The integrated water spray system provides highly effective cooling of the cutting tools, thus extending their service life. Additional features, such as the hydraulically opening scraper blade, dual seats at the rear crawler track units and a pneumatic cutting tool extractor, ensure quick and easy replacement of cutting tools.

HT22 quick-change toolholder system: tools for the pros. >

Optimized toolholder arrangement on the milling drum ensures a clean milling texture. >







- ① Wear markings with 5 mm spacing
- ② 100 % increased maximum wear path
- ③ Increased wear volume in the head
- ④ Wear-resistant head design
- ⑤ Optimised shaft angle geometry for increased component strength
- ⑥ Around 6 % greater shaft cross section for considerably greater resistance to shaft breakage
- ⑦ Protective plugs for screw drive
- ⑧ Optimised screw geometry for simple and safe mating up
- ⑨ Optimised welded joints with increased strength, yet at the same time with enough flexibility for optimum pick rotation
- ⑩ Improved protection of the bottom part thanks to complete coverage of the upper part
- ⑪ Around 67 % greater upper part contact surface to the bottom part for longer bottom part service life
- ⑫ Seal between upper and bottom parts for easy and quick installation and removal of the upper part

# Flexible, high-performance loading of milled material

## The conveyor keeps up with any milling speed

Fast, efficient transport of the milled material off the job site makes a significant contribution to ensure a smooth progress of the milling operation. The loading system of the W 2000 effortlessly copes with transport requirements even when fully utilizing its enormous milling capacity: the conveyor's wide slewing angles enable one truck to wait on the side while another, driving alongside the machine, is still being loaded.

The great discharge height and variable belt speed enable large trucks to be loaded to full capacity. The operator's platform provides a good view of the discharge conveyor and the truck driving in front.







^  
The hydraulically height-adjustable gradation control beam prevents the pavement from breaking into big slabs.

^  
Effectively closed transfer zone from primary to discharge conveyor.

<  
The conveyor in folding design simplifies transport.

>  
The discharge conveyor can be raised hydraulically.



# Optimum traction regardless of the working situation

## Tremendous manoeuvrability

Whether manoeuvring on difficult ground, turning in one go, easy loading or approaching existing cuts in crab steering mode: the excellent driving properties of the W 2000 result in a lucrative time-saving potential. This favourable behaviour is ensured primarily by the smooth, hydraulic all-track steering system with manually selectable, hydraulic flow divider that acts as a differential lock and guarantees uniform traction in particular in adverse conditions.

The individually height-adjustable crawler track units with their high articulation provide ample ground clearance. In addition, all four track units provide large steering angles, which allow the compact W 2000 to perform an amazingly small turning circle.



Crab steering enables the machine to precisely approach existing cuts.

Working independently of the level selected, the parallel sliding block guide ensures precise steering.



Hydraulically opening, hinged engine cowling and wide-opening service panels on both sides.



# Intelligent maintenance pays off



^  
All filters are within easy reach and can be replaced effortlessly.

Ample space for maintenance provided by the wide-open engine cowling. v

## Doing a quick check of the W 2000

Even though the W 2000 has been designed for long working days, a minimum amount of checking and maintenance needs to be done. This is not a big deal at all, however, as all important components are readily accessible without using tools. The wide-opening service panels provide full access to carry out all necessary maintenance and servicing procedures.

In addition, lubrication and service points have been grouped together intelligently in just a few places of the machine, and visual inspections are performed quickly from the operator's platform or from the ground. Ample storage space is available for tools, wearing parts or cutting tools. The overall operational availability of the W 2000 is increased significantly on account of this intelligent maintenance concept.



# High-tech components and state-of-the-art production make for top quality

## Components from manufacturers of good reputation

Over a thousand tried-and-tested W 2000 large milling machines have left the Wirtgen plant to date and have demonstrated their skills on countless job sites around the globe. This wealth of experience is continuously utilized to the benefit of the machine. In the process of selecting components for the W 2000, we additionally consider only those suppliers who meet the highest quality criteria in terms of the durability, failure safety and strength of their products.

A prime example of this is the state-of-the-art, economical diesel engine. The fully electronic machine control system ensures that it always works in the optimal performance and torque ranges. This minimizes fuel consumption and directly results in low operating cost.

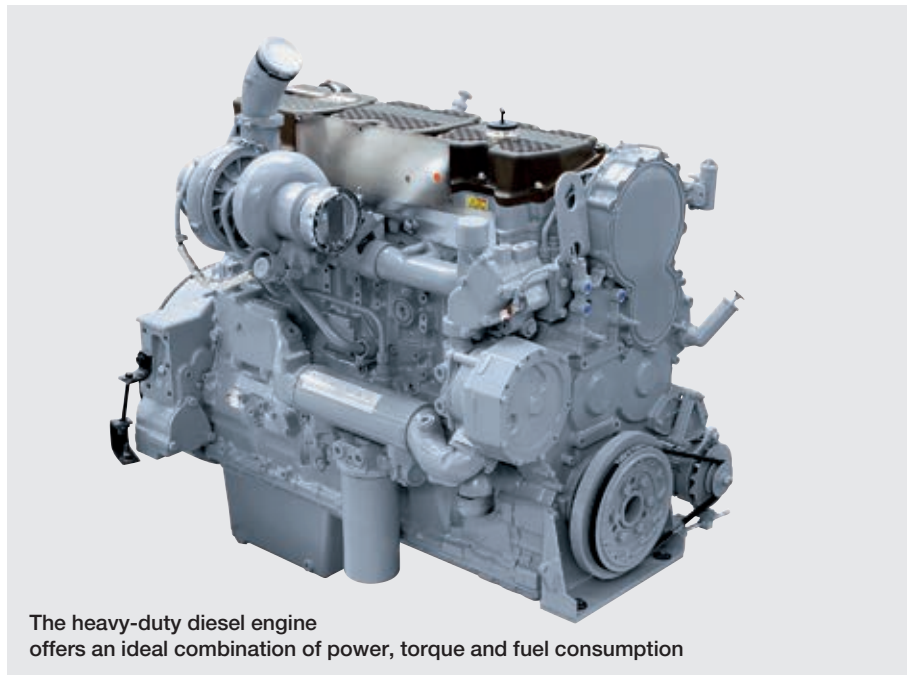

The heavy-duty diesel engine offers an ideal combination of power, torque and fuel consumption

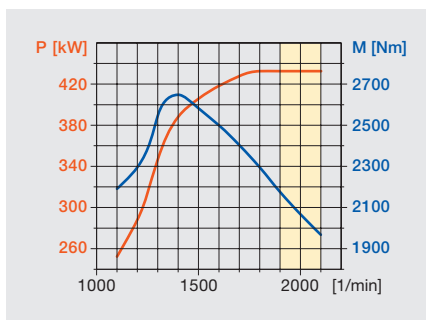

Ideal characteristic curve: the engine output remains constant even at extreme engine lugging.



“Made in Germany” – electrical cabinet and hydraulic system.

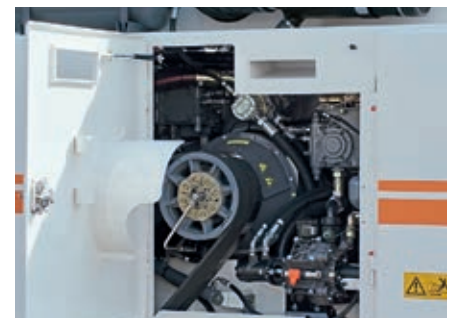



Engineering and design  
in the German main plant.



Final assembly is performed  
by skilled expert staff.



## High quality, worldwide customer service

- › Highly qualified German engineers and technicians are in charge of the engineering and design of the W 2000 machine.
- › The machines are manufactured in state-of-the-art production facilities by highly qualified expert staff and in mature production processes.
- › The global Wirtgen service network enables service technicians to be on site quickly, no matter how remote the job site is.
- › The high-quality original spare parts from Wirtgen can also be supplied worldwide and on short notice.

# Technical specification W 2000

Milling drum	
Milling width	2,000 mm
Milling depth *1	0–320 mm
Tool spacing	15 mm
Number of tools	162
Drum diameter with tools	980 mm
Engine	
Manufacturer	Caterpillar
Type	C 15 ATAAC
Cooling	water
Number of cylinders	6
Rated power at 2,000 min <sup>-1</sup>	433 kW/581 HP/589 PS
Maximum power at 1,800 min <sup>-1</sup>	350 kW/469 HP/476 PS
Displacement	15.21 l
Fuel consumption, full load	124 l/h
Fuel consumption in field mix	50 l/h
Emission standards	EPA Tier 3, EC Stage 3a
Electrical system	24 V
Tank capacities	
Fuel tank	1,310 l
Hydraulic fluid tank	300 l
Water tank	3,430 l
Driving properties	
Travel speed in milling gear, max.	0–84 m/min
Travel speed in travel gear, max.	0–5 km/h
Crawler tracks	
Crawler tracks (L x W x H)	1,720 x 300 x 610 mm
Loading the milled material	
Belt width of primary conveyor	800 mm
Belt width of discharge conveyor	800 mm
Theoretical capacity of discharge conveyor	330 m <sup>3</sup> /h
Shipping dimensions	
Machine (L x W x H)	7,200 x 2,585 x 3,000 mm
Discharge conveyor (L x W x H)	8,550 x 1,370 x 1,300 mm

\*1 = The maximum milling depth may deviate from the value indicated, due to tolerances and wear.



# Equipment features of W 2000

## Standard equipment

### Basic machine

- › Water cooler with temperature-related fan speed
- › Lockable, hydraulically opening engine cowling with integrated soundproofing package
- › Air compressor system
- › Standard painting in Wirtgen white with orange stripes

### Milling drum assembly

- › Milling drum housing for milling width 2,000 mm, made entirely of wear plates
- › Additional control switches for scraper blade at ground level

### Milling drums

- › Milling drum, milling width 2,000 mm, tool spacing 15 mm, in welded double-pin toolholder design

### Loading of milled material

- › Two-stage loading system with 800 mm wide conveyor belt
- › Discharge conveyor slewing angle of 45 degrees left and right
- › Conveyor system with adjustable conveying speed

### Machine and levelling control

- › Proportional advance speed control across the entire speed range via joystick
- › Automatic power control for optimum power adjustment to different pavement materials
- › Engageable hydraulic traction control (flow divider)
- › Freely selectable steering mode for crawler tracks

### Operator's platform

- › WIDIS 32 multifunctional display with error code indication in the right-hand control panel
- › Lockable control panel covers

### Chassis and height adjustment

- › Wear-resistant polyurethane track pad equipment
- › Continuously adjustable, hydraulic all-track drive with hydraulic differential lock
- › Height adjustment via proportional valve control

### Miscellaneous

- › Lighting package with 10 spotlights
- › Comprehensive safety package with 6 emergency stop switches
- › Lockable toolbox with comprehensive toolkit for servicing and maintenance
- › Warranty of 12 months or 1,000 engine operating hours

## Optional equipment

### Basic machine

- › Special painting in one or several colours

### Milling drum assembly

- › Milling drum housing for milling width 2,000 mm, FCS Light

### Milling drums

- › Milling drum, milling width 2,000 mm, tool spacing 8 mm, HT22 quick-change toolholder system in FCS Light design
- › Milling drum, milling width 2,000 mm, tool spacing 6x2 mm, HT5 welded toolholder system in FCS Light design
- › Pneumatic cutting tool driver and extractor

### Loading of milled material

- › Hydraulically operated folding discharge conveyor, long

### Machine and levelling control

- › LEVEL PRO automatic levelling system with 2 wire-rope sensors
- › Electronic slope sensor

### Operator's platform

- › Stable, soundproof GRP canopy with folding rear screen; canopy can be fully lowered hydraulically

### Miscellaneous

- › Hydraulically operated high-pressure water cleaner (max. 200 bar)

# Technical specification W 2000

## Dimensions in mm

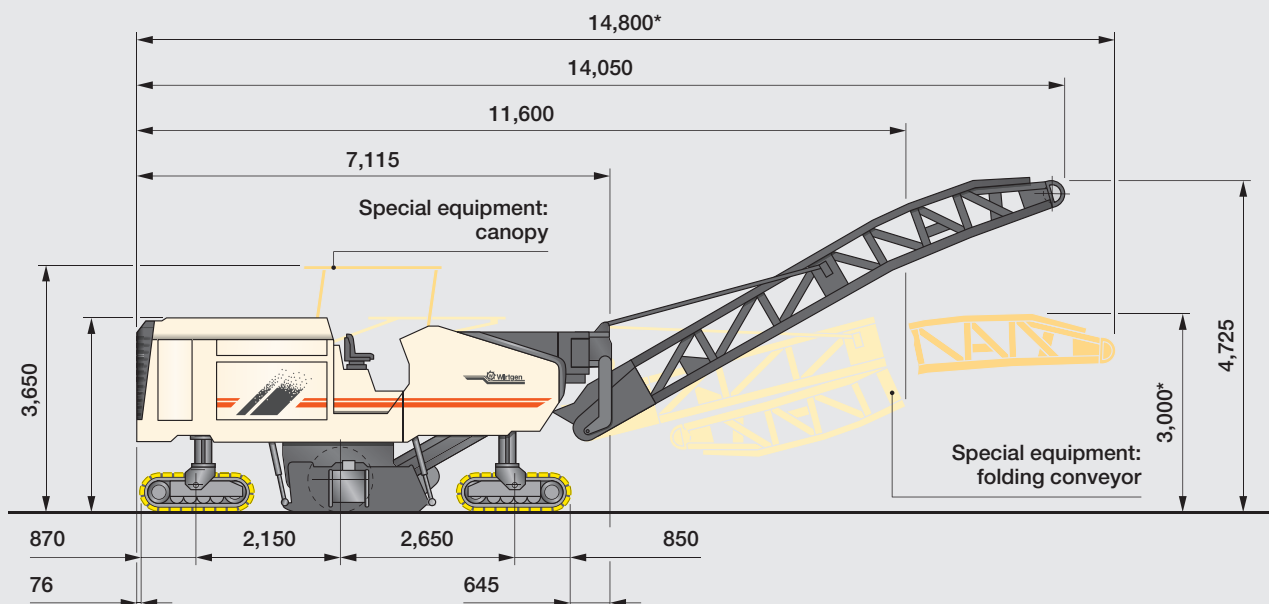

\* = Dimensions for low-loader transport

Machine weights	
Empty weight of machine without filling media, without conveyor	27,700 kg
Operating weight, CE*	30,000 kg
Operating weight, max. (full tanks, full range of equipment)	33,427 kg
Weights of filling media	
Water tank filling in kg	3,430 kg
Diesel tank filling in kg (0.83 kg/l)	1,087 kg
Optional equipment features increasing / reducing empty weight	
Driver and tools	
Driver	75 kg
Weight of 5 cutting tool containers	125 kg
On-board tools	30 kg



**Optional equipment features increasing/reducing empty weight**

**Optional milling drums in lieu of standard**

Milling assembly and milling drum, milling width 2,200 mm	300 kg
Milling assembly and milling drum in FCS Light design, milling width 2,000 mm	600 kg

**Optional additional equipment**

Canopy in lieu of standard	250 kg
Folding conveyor in lieu of standard	360 kg

**Dimensions in mm**

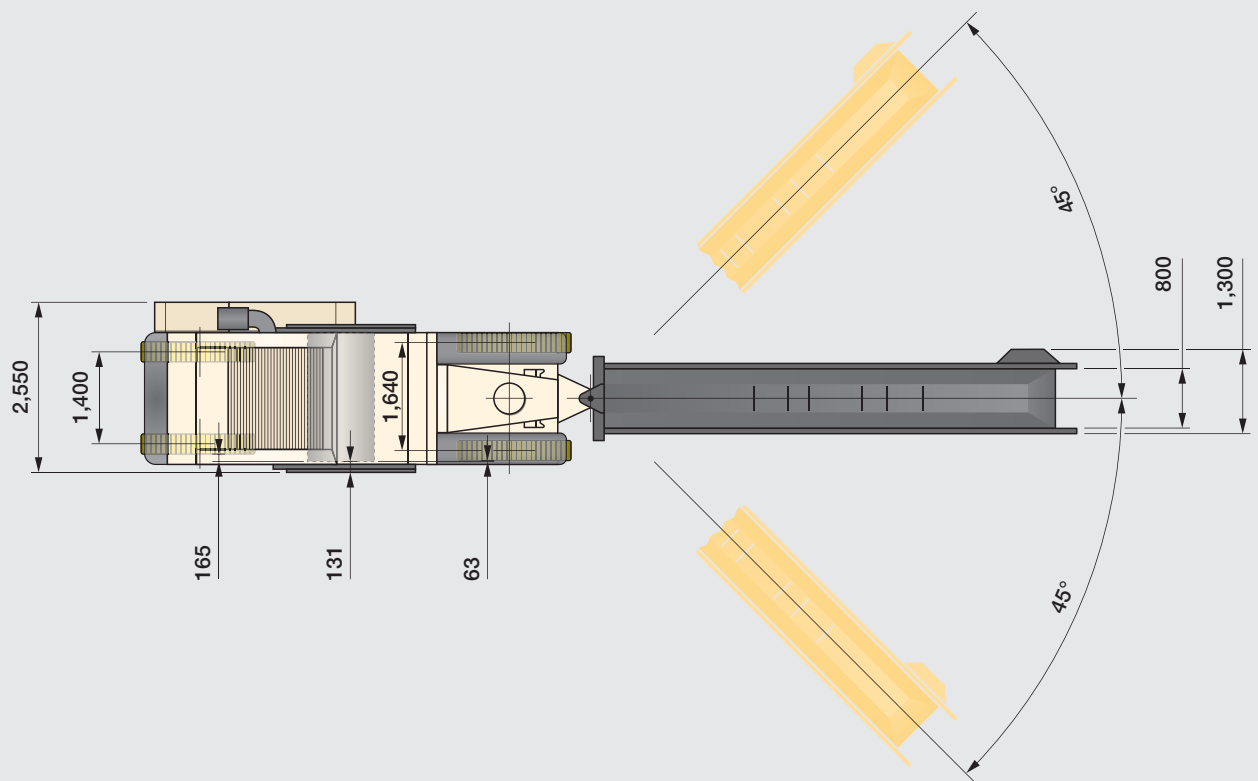

\* = Dimensions for low-loader transport



Wirtgen GmbH  
Reinhard-Wirtgen-Strasse 2 · 53578 Windhagen · Germany  
Phone: +49 (0) 26 45 / 131-0 · Fax: +49 (0) 26 45 / 131-392  
Internet: [www.wirtgen.com](http://www.wirtgen.com) · E-Mail: [info@wirtgen.com](mailto:info@wirtgen.com)